

# INSTALLATION



## IS110 Series Camclosure®



**Integrated Camera System**

**C3426M-A (5/07)**



# Contents

---

Regulatory Notices . . . . .	5
Description . . . . .	6
Models . . . . .	6
Parts List . . . . .	8
Cover and Back Box Installation . . . . .	10
Unshielded Twisted Pair (UTP) Video . . . . .	10
Basic Surface Installation . . . . .	10
4S Electrical Box Installation . . . . .	11
404 Plaster Ring Installation . . . . .	13
Side Conduit Installation . . . . .	14
Camera Module . . . . .	16
Module Removal . . . . .	16
Camera Orientation . . . . .	18
Module Installation . . . . .	18
Camera Adjustments . . . . .	19
Varifocal Lens Zoom and Focus Adjustments . . . . .	19
DN/CH Series Adjustments . . . . .	20
Switch Settings . . . . .	20
Auto Iris Level Adjustment . . . . .	21
Vertical Phase Adjustment . . . . .	22
Blemish Detection . . . . .	22
Day/Night Operation . . . . .	23
DW/CW Series (Wide Dynamic Range) Adjustments . . . . .	24
Switch Settings . . . . .	24
Auto Iris Level Adjustment . . . . .	26
Vertical Phase Adjustment . . . . .	27
Blemish Detection . . . . .	27
Camera Positioning . . . . .	28
Install Liner and Trim Ring . . . . .	29
Service Connector . . . . .	30
Specifications . . . . .	32

# List of Illustrations

---

1	Package Components	9
2	Basic Surface Installation	11
3	4S Electrical Box Installation	12
4	404 Plaster Ring Installation	14
5	Side Conduit Installation	15
6	Camera Module Bracket	16
7	Back Box Connectors	17
8	Camera Orientation	18
9	Location of Zoom and Focus Adjustments	19
10	Adjusting the IS110-DN/CH Series Camclosure	20
11	Threshold Switching Levels	23
12	Adjusting the IS110-DW/CW Series Camclosure	24
13	Threshold Switching Levels	26
14	Positioning the Camera	28
15	Adjusting the Liner	29
16	Service Connector	30
17	Attaching the 2.5 mm Monaural Headphone Plug	31

# Regulatory Notices

---

This device complies with Part 15 of the FCC Rules. Operation is subject to the following two conditions: (1) this device may not cause harmful interference, and (2) this device must accept any interference received, including interference that may cause undesired operation.

## RADIO AND TELEVISION INTERFERENCE

This equipment has been tested and found to comply with the limits of a Class B digital device, pursuant to Part 15 of the FCC Rules. These limits are designed to provide reasonable protection against harmful interference in a residential installation. This equipment generates, uses, and can radiate radio frequency energy and, if not installed and used in accordance with the instructions, may cause harmful interference to radio communications. However there is no guarantee that the interference will not occur in a particular installation. If this equipment does cause harmful interference to radio or television reception, which can be determined by turning the equipment off and on, the user is encouraged to try to correct the interference by one or more of the following measures:

- Reorient or relocate the receiving antenna.
- Increase the separation between the equipment and the receiver.
- Connect the equipment into an outlet on a circuit different from that to which the receiver is connected.
- Consult the dealer or an experienced radio/TV technician for help.

You may also find helpful the following booklet, prepared by the FCC: "How to Identify and Resolve Radio-TV Interference Problems." This booklet is available from the U.S. Government Printing Office, Washington D.C. 20402.

Changes and modifications not expressly approved by the manufacturer or registrant of this equipment can void your authority to operate this equipment under Federal Communications Commission's rules.

This Class B digital apparatus complies with Canadian ICES-003.

Cet appareil numérique de la classe B est conforme à la norme NMB-003 du Canada.



**WARNING:** This product is sensitive to Electrostatic Discharge (ESD). To avoid ESD damage to this product, use ESD safe practices during installation. Before touching, adjusting or handling this product, correctly attach an ESD wrist strap to your wrist and appropriately discharge your body and tools. For more information about ESD control and safe handling practices of electronics, please refer to ANSI/ESD S20.20-1999 or contact the Electrostatic Discharge Association ([www.esda.org](http://www.esda.org)).



The materials used in the manufacture of this document and its components are compliant to the requirements of Directive 2002/95/EC.



This equipment contains electrical or electronic components that must be recycled properly to comply with Directive 2002/96/EC of the European Union regarding the disposal of waste electrical and electronic equipment (WEEE). Contact your local dealer for procedures for recycling this equipment.

# Description

The IS110 Series Camclosure® integrated camera system combines an environmental cover, back box, camera, lens, and lower dome into a small, high-security system that is quick and easy to install. The system is perfect for a variety of indoor and outdoor applications and its versatile design allows for multiple mounting options. The unit supports both BNC and unshielded twisted pair (UTP) video wiring.

The IS110 Series Camclosure integrated camera system can be installed directly to a ceiling, wall, 4S electrical box (using the optional ICS110-AP adapter plate), or a standard plaster ring. The system has three conduit openings: two in the base and a threaded 0.75-inch (1.91 cm) opening in the side.

Before installing your new system, thoroughly familiarize yourself with the information in this manual.

## MODELS

Indoor/outdoor dome, vandal resistant, surface mount, smoked bubble, gray finish

Camera Type	Lens/Iris	NTSC	PAL
Color, Wide Dynamic Range, Day/Night	3-9.5 mm, Day/Night Varifocal, Auto Iris	IS110-DWV9	
	9-22 mm, Day/Night Varifocal, Auto Iris	IS110-DWV22	
Color, High Resolution, Day/Night	3-9.5 mm, Day/Night Varifocal, Auto Iris	IS110-DNV9	IS110-DNV9X
	9-22 mm, Day/Night Varifocal, Auto Iris	IS110-DNV22	IS110-DNV22X
Color, Wide Dynamic Range	3-9.5 mm, Varifocal, Auto Iris	IS110-CWV9	
	9-22 mm, Day/Night Varifocal, Auto Iris	IS110-CWV22	
Color, High Resolution	3-9.5 mm, Varifocal, Auto Iris	IS110-CHV9	IS110-CHV9X
	9-22 mm, Varifocal, Auto Iris	IS110-CHV22	IS110-CHV22X
	3.0 mm, Fixed, Manual Iris	IS110-CH3	IS110-CH3X
	3.6 mm, Fixed, Manual Iris	IS110-CH3.6	IS110-CH3.6X
	6.0 mm, Fixed, Manual Iris	IS110-CH6	IS110-CH6X
	8.0 mm, Fixed, Manual Iris	IS110-CH8	IS110-CH8X
12.0 mm, Fixed, Manual Iris	IS110-CH12	IS110-CH12X	

Indoor/outdoor dome, vandal resistant, surface mount, clear bubble, liner, gray finish

<b>Camera Type</b>	<b>Lens/Iris</b>	<b>NTSC</b>	<b>PAL</b>
Color, Wide Dynamic Range, Day/Night	3-9.5 mm, Day/Night Varifocal, Auto Iris	IS111-DWV9	
	9-22 mm, Day/Night Varifocal, Auto Iris	IS111-DWV22	
Color, High Resolution, Day/Night	3-9.5 mm, Day/Night Varifocal, Auto Iris	IS111-DNV9	IS111-DNV9X
	9-22 mm, Day/Night Varifocal, Auto Iris	IS111-DNV22	IS111-DNV22X
Color, Wide Dynamic Range	3-9.5 mm, Varifocal, Auto Iris	IS111-CWV9	
	9-22 mm, Day/Night Varifocal, Auto Iris	IS111-CWV22	
Color, High Resolution	3-9.5 mm, Varifocal, Auto Iris	IS111-CHV9	IS111-CHV9X
	9-22 mm, Varifocal, Auto Iris	IS111-CHV22	IS111-CHV22X
	3.0 mm, Fixed, Manual Iris	IS111-CH3	IS111-CH3X
	3.6 mm, Fixed, Manual Iris	IS111-CH3.6	IS111-CH3.6X
	6.0 mm, Fixed, Manual Iris	IS111-CH6	IS111-CH6X
	8.0 mm, Fixed, Manual Iris	IS111-CH8	IS111-CH8X
	12.0 mm, Fixed, Manual Iris	IS111-CH12	IS111-CH12X

# PARTS LIST

<b>Qty</b>	<b>Description</b>
------------	--------------------

- |   |  |
|---|--|
| 1 | IS110 Series Camclosure integrated camera system <ul style="list-style-type: none"><li>• Cover and back box (assembled)</li><li>• Trim ring with bubble; clear bubble models include a liner</li><li>• Camera module</li></ul> |
| 1 | Black plug   |
| 1 | 1/8-inch hollow screwdriver bit  |
| 2 | 8-32 x 0.375-inch Phillips pan head screws with washers (attached to cover and back box)   |
| 3 | 6-32 x 0.75-inch Phillips pan head screws  |
| 2 | 8-32 x 0.75-inch Phillips flat head screws   |
| 2 | 8-32 x 0.75-inch Phillips pan head screws  |



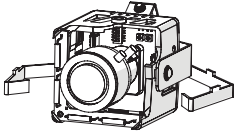

CAMERA MODULE  
(1)



COVER AND  
BACK BOX (1)

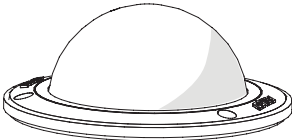

TRIM RING AND  
SMOKED BUBBLE  
(1)

< OR >

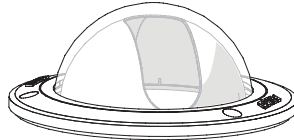

TRIM RING, LINER,  
AND CLEAR BUBBLE  
(1)



BLACK PLUG  
(1)



1/8-INCH HOLLOW  
SCREWDRIVER BIT (1)

SHOWN ACTUAL SIZE

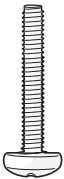

6-32 X 0.75-INCH  
PHILLIPS PAN HEAD  
SCREWS (3)



8-32 X 0.75-INCH  
PHILLIPS FLAT HEAD  
SCREWS (2)



8-32 X 0.75-INCH  
PHILLIPS PAN HEAD  
SCREWS (2)



8-32 X 0.375-INCH  
PHILLIPS PAN HEAD  
SCREWS WITH  
WASHERS (2 EACH)

Figure 1. Package Components

# Cover and Back Box Installation

---

The IS110 Series Camclosure integrated camera system mounts only to a surface. It can be wired through the cover into a surface, electrical box, or plaster ring. You can also wire it through a side conduit.

## UNSHIELDED TWISTED PAIR (UTP) VIDEO

The IS110 Series offers support for unshielded twisted pair (UTP). The UTP video output signal is 1 V<sub>p-p</sub> differential into a 100-ohm load. At a minimum, UTP requires Cat5, 100-ohm twisted pair cable.

## BASIC SURFACE INSTALLATION

**NOTE:** You should install the camera module into the back box before installing the back box into the cover. When installing the back box into the cover, rotate the camera module to access the mounting holes (refer to *Camera Module* on page 16 for more information).

1. Remove the two 8-32 x 0.375-inch Phillips pan head screws and washers to separate the cover from the back box.
2. Using the cover as a template, mark one of the large holes on the mounting surface.
3. Cut out the hole for the power and video wiring.
4. Pull the video and power wires through the hole in the cover.
5. Attach the cover to the mounting surface (hardware not supplied). Use stainless steel hardware when installing the system outdoors.
6. Connect the video cable/wires:
  - **BNC:** Connect the BNC connector from the unit to a mating BNC connector.
  - **UTP:** Blue wire = Video +  
Gray wire = Video -
7. Connect the power wires.

Voltage	Red Wire	Black Wire
12 VDC	+	Ground
24 VAC	~	~

*AC operation only:* If you are wiring more than one Camclosure to the same transformer, connect one side of the transformer to the red wire on all units; connect the other side of the transformer to the black wire on all units.

**NOTE:** Failure to connect all AC powered units the same way will cause the cameras to be out of phase with each other and may produce a vertical roll when switching between cameras.

8. Reinstall the back box inside the cover. For vandal-resistant installations, rotate the back box to position the conduit plug opposite the notch on the side of the cover. Use the two 8-32 x 0.375-inch Phillips pan head screws and washers (removed earlier) to secure the back box to the cover.

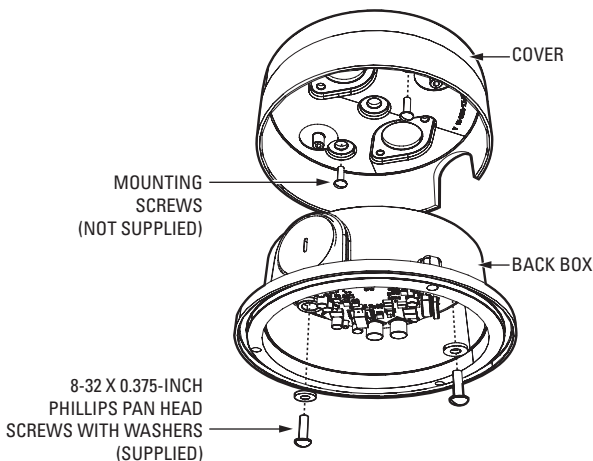

**Figure 2.** Basic Surface Installation

## 4S ELECTRICAL BOX INSTALLATION

**NOTE:** You should install the camera module into the back box before installing the back box into the cover. When installing the back box into the cover, rotate the camera module to access the mounting holes (refer to *Camera Module* on page 16 for more information).

1. Attach an ICS110-AP adapter plate (not supplied) to a 4S box. Use two 8-32 x 0.75-inch Phillips flat head screws (supplied with both the IS110 and the adapter plate).
2. Remove the two 8-32 x 0.375-inch Phillips pan head screws and washers to separate the cover from the back box.
3. Pull the video and power wires into the cover.
4. Attach the cover to the adapter plate with up to four 8-32 x 0.375-inch Phillips pan head screws (supplied with the adapter plate). Use stainless steel hardware when installing the system outdoors.
5. Connect the video cable/wires:
  - **BNC:** Connect the BNC connector from the unit to a mating BNC connector.
  - **UTP:** Blue wire = Video +  
Gray wire = Video -

- Connect the power wires.

Voltage	Red Wire	Black Wire
12 VDC	+	Ground
24 VAC	~	~

*AC operation only:* If you are wiring more than one Camclosure to the same transformer, connect one side of the transformer to the red wire on all units; connect the other side of the transformer to the black wire on all units.

**NOTE:** Failure to connect all AC powered units the same way will cause the cameras to be out of phase with each other and may produce a vertical roll when switching between cameras.

- Reinstall the back box inside the cover. For vandal-resistant installations, rotate the back box to position the conduit plug opposite the notch on the side of the cover. Use the two 8-32 x 0.375-inch Phillips pan head screws and washers (removed earlier) to secure the back box to the cover.

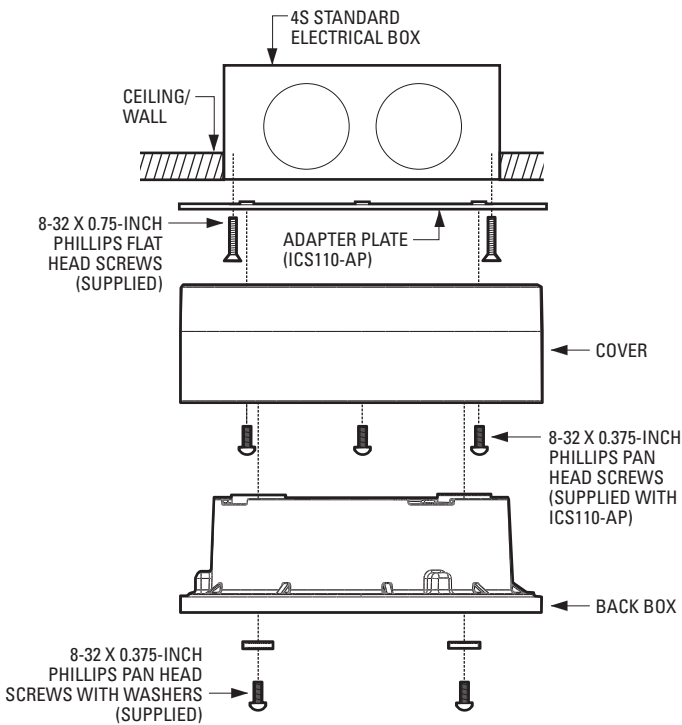

**Figure 3.** 4S Electrical Box Installation

## 404 PLASTER RING INSTALLATION

**NOTE:** You should install the camera module into the back box before installing the back box into the cover. When installing the back box into the cover, rotate the camera module to access the mounting holes (refer to *Camera Module* on page 16 for more information).

1. Remove the two 8-32 x 0.375-inch Phillips pan head screws and washers to separate the cover from the back box.
2. Pull video and power wires into the cover. Use up to three supplied 6-32 x 0.75-inch Phillips pan head screws or two supplied 8-32 x 0.75-inch Phillips pan head screws to attach the cover to an installed 404 plaster ring. Use stainless steel hardware when installing the system outdoors.
3. Connect the video cable/wires:
  - **BNC:** Connect the BNC connector from the unit to a mating BNC connector.
  - **UTP:** Blue wire = Video +  
Gray wire = Video -
4. Connect the power wires.

Voltage	Red Wire	Black Wire
12 VDC	+	Ground
24 VAC	~	~

*AC operation only:* If you are wiring more than one Camclosure to the same transformer, connect one side of the transformer to the red wire on all units; connect the other side of the transformer to the black wire on all units.

**NOTE:** Failure to connect all AC powered units the same way will cause the cameras to be out of phase with each other and may produce a vertical roll when switching between cameras.

- Reinstall the back box inside the cover. For vandal-resistant installations, rotate the back box to position the conduit plug opposite the notch on the side of the cover. Use the two 8-32 x 0.375-inch Phillips pan head screws and washers (removed earlier) to secure the back box to the cover.

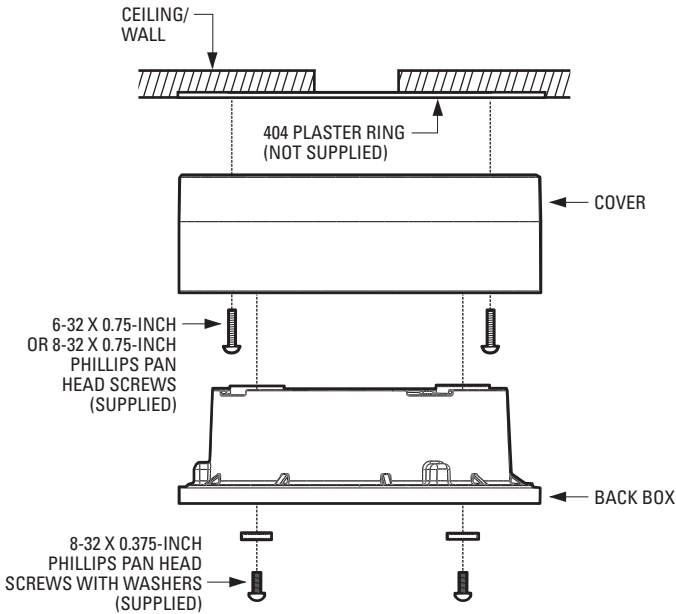

**Figure 4.** 404 Plaster Ring Installation

## SIDE CONDUIT INSTALLATION

**NOTE:** You should install the camera module into the back box before installing the back box into the cover. When installing the back box into the cover, rotate the camera module to access the mounting holes (refer to *Camera Module* on page 16 for more information).

- Remove the two 8-32 x 0.375-inch Phillips pan head screws and washers to separate the cover from the back box.
- Attach the cover to the mounting surface (hardware not supplied). Use stainless steel hardware when installing the system outdoors.
- Remove the conduit plug from the side of the back box.
- Use a blunt tool to pull the wires and plug, located on the base of the back box, into the back box.
- Insert the black plug (supplied) into the hole in the base of the back box.
- Reinstall the back box inside the cover. Line up the conduit plug with the notch on the side of the cover. Use the two 8-32 x 0.375-inch Phillips pan head screws and washers (removed earlier) to secure the back box to the cover.

- Install a 0.75-inch (1.91 cm) threaded conduit connector (not supplied) into the conduit hole in the back box.

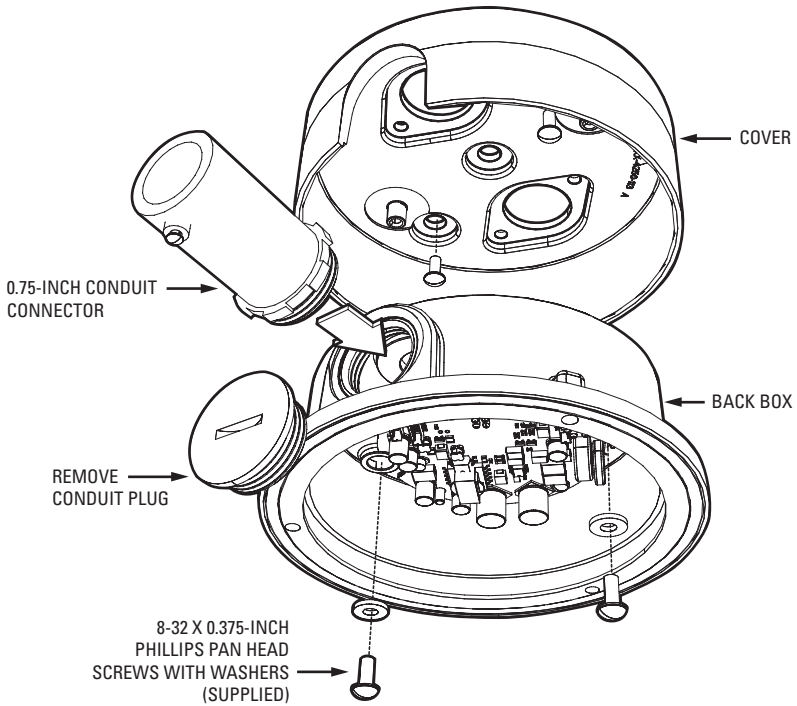

**Figure 5. Side Conduit Installation**

- Connect the video cable/wires:
  - BNC:** Connect the BNC connector from the unit to a mating BNC connector.
  - UTP:** Blue wire = Video +  
Gray wire = Video -
- Connect the power wires.

Voltage	Red Wire	Black Wire
12 VDC	+	Ground
24 VAC	~	~

*AC operation only:* If you are wiring more than one Camclosure to the same transformer, connect one side of the transformer to the red wire on all units; connect the other side of the transformer to the black wire on all units.

**NOTE:** Failure to connect all AC powered units the same way will cause the cameras to be out of phase with each other and may produce a vertical roll when switching between cameras.

# Camera Module

---

The IS110 Series Camclosure camera module includes the camera, camera bracket, and heater board. To perform most camera adjustments, you must remove the module from the back box.

Use the following instructions to remove and reinstall the camera module.

**⚠ WARNING:** Heater elements could be hot! When camera power is on, use caution when adjusting the camera. This applies to all models.

## MODULE REMOVAL

To remove the camera module from the back box:

1. Gently squeeze the bracket and pull the module out of the back box (refer to Figure 6).

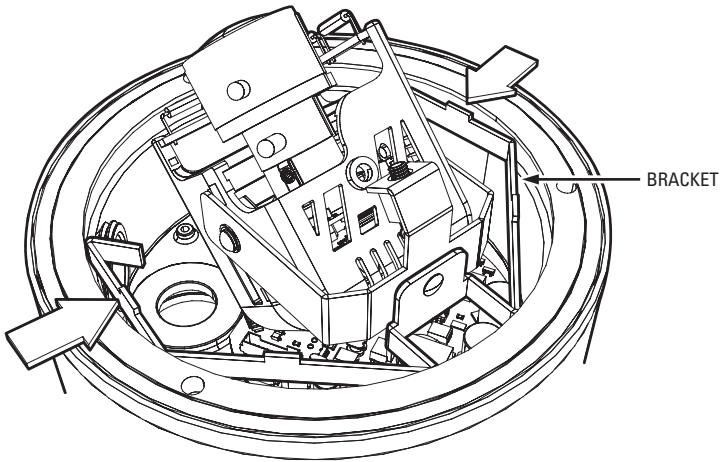

**Figure 6.** Camera Module Bracket



2. Unplug the camera (10-pin), service (3-pin), and heater board (4-pin) connectors from the back box (refer to Figure 7).

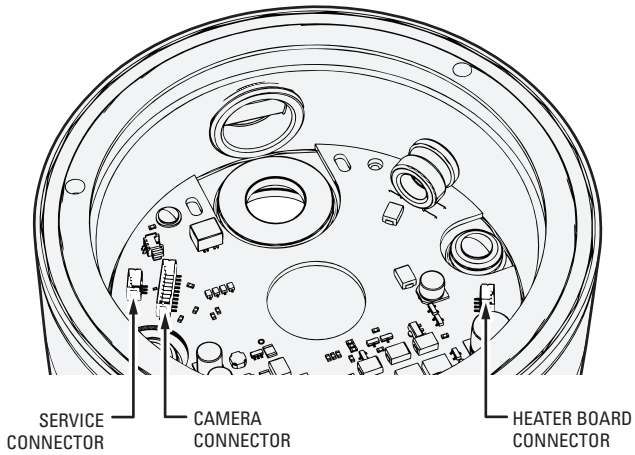

**Figure 7. Back Box Connectors**

## CAMERA ORIENTATION

At the factory, the camera module is configured for ceiling mounting. For wall mounting, you must change the camera orientation or the video image could be upside down or sideways.

To change the camera orientation (refer to Figure 8):

1. Remove the camera module from the back box if necessary.
2. Remove the tilt adjustment screw and lock washer from each side of the camera.
3. Carefully rotate the camera one quarter or one half turn, depending on desired camera angle.

### NOTES:

- Make sure to orient the top of the camera to the top of the field of view.
  - Make sure the wiring harness does not bind.
  - Make sure to orient the service connector away from the back box.
4. Reinstall the tilt adjustment screw and lock washer on each side of the camera.
  5. Verify the camera orientation.

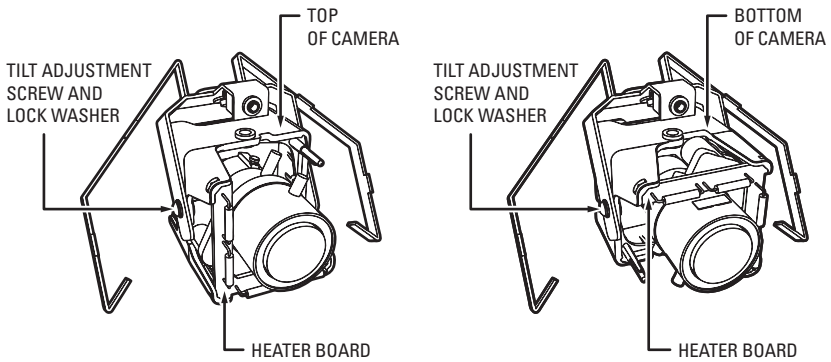

**Figure 8.** Camera Orientation

## MODULE INSTALLATION

To install the camera module into the back box:

1. Plug the connectors into the back box in the following order (refer to Figure 7 on page 17):
  - Service (3-pin) connector
  - Camera (10-pin) connector
  - Heater board (4-pin) connector
2. Make sure the tabs on the camera bracket and the service connector are pointing out of the enclosure, away from the ceiling or wall.
3. Gently squeeze the bracket, place it against the groove inside the back box, and gently release (refer to Figure 6 on page 16).

# Camera Adjustments

To perform the following camera adjustments, make sure to plug in the camera and service connectors. You may have to remove the camera module from the back box.

Connect a monitor. Then turn on power to the camera and monitor. To use the service connector, refer to *Service Connector* on page 30.

To set the DIP switches, or to adjust the auto iris level (DN or CH) or the vertical phase (DW or CW), you will need a miniature trimpot adjustment tool with a 0.05-inch (1.27 mm) blade. Suggested tools include a miniature flat-tip screwdriver, a Philmore trimpot tool (#63-8608), and the Philmore 10-piece tool set (#63-910). To adjust the lens, you may also need a miniature Phillips screwdriver.

After you have adjusted the unit, reinstall the camera module into the back box, and install the trim ring, bubble, and liner (if necessary).

## VARIFOCAL LENS ZOOM AND FOCUS ADJUSTMENTS

To adjust the field of view and the focus (refer to Figure 9):

**NOTE:** You may need a miniature Phillips or flat-tip screwdriver to loosen and tighten the locking screws.

1. Loosen the zoom locking screw.
2. Turn the zoom adjustment ring clockwise or counterclockwise to select the field of view.
3. Tighten the zoom locking screw.
4. Loosen the focus locking screw.
5. Turn the focus locking screw clockwise or counterclockwise to adjust the focus.
6. Tighten the focus locking screw.

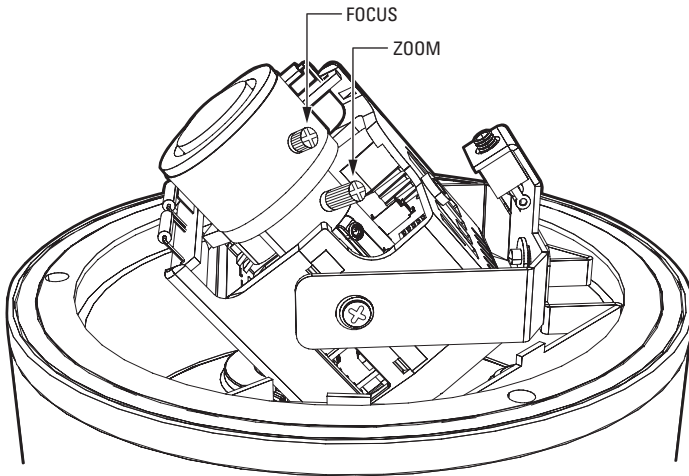

**Figure 9.** Location of Zoom and Focus Adjustments

# DN/CH SERIES ADJUSTMENTS

Refer to Figure 10 to adjust the IS110-DN or IS110-CH model.

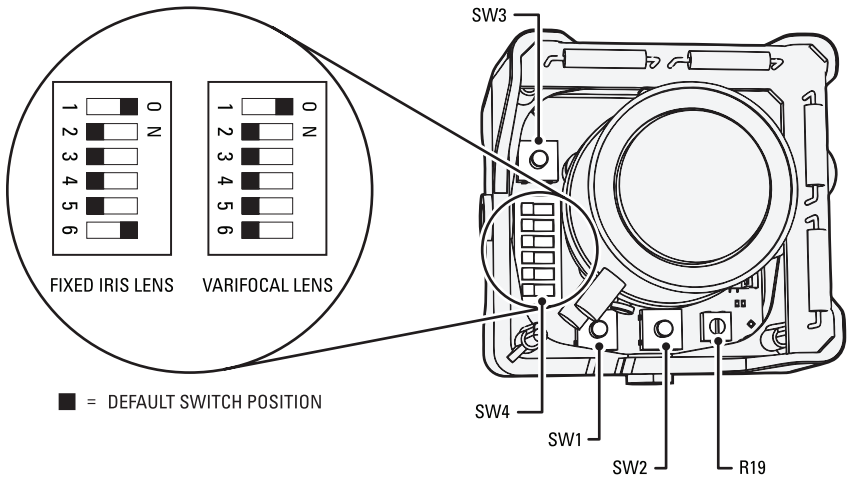

**Figure 10.** Adjusting the IS110-DN/CH Series Camclosure

## SWITCH SETTINGS

Locate the DIP switch. Then set the switches for your installation.

### SW4-1: AGC (Auto Gain Control)

The AGC (automatic gain control) adjusts the image automatically to compensate for changes in light levels.

Set to ON to enable AGC. Set to OFF to disable AGC. The default is ON.

### SW4-2: BLC (Backlight Compensation)

The BLC (backlight compensation) feature compensates for backlit scenes by enhancing objects in the center of the scene.

Set to ON to enable BLC. Use this setting if a bright backlight is present and the subject in the center of the picture appears dark or as a silhouette.

Set to OFF to disable backlight compensation. This is the default.

### SW4-3: Line Sync

When multiple cameras are connected to the same switching device, vertical roll may occur on the monitor. AC line lock eliminates vertical roll by locking the frame rate to the power supply frequency. Each camera output is synchronized to the power supply frequency. (Refer to *Vertical Phase Adjustment* on page 22 for more information.)

Internal line sync disables line lock and synchronizes cameras internally.

Set to OFF to use AC line lock. Set to ON to use internal line sync. The default is OFF.

#### **SW4-4: Flickerless**

In certain lighting conditions, a flicker in the light source may affect camera operation. Flickering can be caused by a number of conditions, including the quality of the source power and the age and type of fluorescent bulbs and ballasts.

Set to ON to enable flickerless operation. The camera will remove the effects of flickering when present. The shutter speed will be set to 1/120 (NTSC) or 1/100 (PAL).

Set to OFF to disable flickerless operation. This is the default.

**NOTE:** If you enable flickerless operation, you should use AC line lock for best results.

#### **SW4-5: AWB (Auto White Balance)/MWB (Manual White Balance)**

Auto white balance is enabled by default (OFF).

To manually set and lock the white balance:

1. Set SW4-5 to OFF.
2. Hold a white background in front of the lens until the video shows all white.
3. While holding the background in place, set SW4-5 to ON. A blue blinking block appears on the video image for a few seconds. When the block changes to solid green, the manual white balance process is complete.

#### **SW4-6: Reserved**

Do not change SW4-6 from its factory setting. SW4-6 must be set to OFF for Varifocal models; it must be set to ON for fixed-iris lenses.

### **AUTO IRIS LEVEL ADJUSTMENT**

To adjust the auto iris DC-drive level (refer to Figure 10 on page 20):

1. Tilt or rotate the camera module until you can access the auto iris level control (R19).
2. Turn the screw clockwise to increase the brightness level or counterclockwise to decrease the brightness level.

## VERTICAL PHASE ADJUSTMENT

**NOTE:** Use this procedure for 24 VAC operation only.

When using more than one camera power supply, a brief vertical roll may occur on the monitor when switching from one camera to another.

To eliminate vertical roll, reverse the 24 VAC connections on one camera. If both cameras are connected to the same transformer, this should solve the problem. If the problem still exists, adjust the phase control by synchronizing, or line-locking, the cameras to one another.

**NOTE:** When adjusting vertical phase, line sync (SW4-3) must be set to OFF for AC line lock.

### Adjusting Vertical Phase

You may need two people when synchronizing the cameras: one at the camera, the other at the monitor to observe the vertical roll and the effect of any camera adjustments.

To synchronize the cameras:

1. Choose a reference camera to which all other cameras will be phased.
2. Select the camera to synchronize. Use buttons SW1 and SW2 to synchronize the camera to the reference camera (refer to Figure 10 on page 20). SW1 increases vertical phase; SW2 decreases vertical phase.
3. Each time an adjustment is made, switch back and forth between the camera you are adjusting and the reference camera. Repeat this process as many times as necessary until the roll between the cameras is no longer noticeable.
4. Adjust the phase of all other cameras by repeating steps 2 through 3. Always adjust to the reference camera selected in step 1.

**NOTE:** The preferred method for camera phase adjustment is to use a dual trace oscilloscope to align the vertical sync pulses of the reference camera to the selected camera(s).

## BLEMISH DETECTION

If small white or color spots appear in the video image, one or more pixels on the camera imager may be defective. (This condition is common for both CCD and CMOS imagers.)

DN and CH Series cameras with auto iris lenses automatically detect and correct defective pixels during startup. Video turns on, then off, and then on again. If white or color spots still appear, you can correct the defective pixels manually.

CH Series cameras with fixed iris lenses do not automatically detect and correct defective pixels. You can correct the defective pixels manually.

To manually correct defective pixels (refer to Figure 10 on page 20):

1. Cover the lens completely. Make sure no light can enter the lens.  
**NOTE:** The mechanical iris lens aperture does not completely block the light.
2. Press and hold button SW3 for one second. The camera will find and correct defective pixels.  
**NOTE:** Any defective pixels that cannot be completely corrected may still appear.
3. Release button SW3.
4. Uncover the lens for normal camera operation.

# DAY/NIGHT OPERATION

**NOTE:** This section only applies to DN model cameras.

DN model cameras regularly check the brightness level of the field of view to determine when to switch between day (color) and night (black-white) operation.

Actual brightness threshold levels are affected by camera angle, amount of zoom, field of view, lens, and type of lighting. The switching process lasts from seven to 10 seconds.

Figure 11 and Table A show how the camera switches between color and black-white operation.

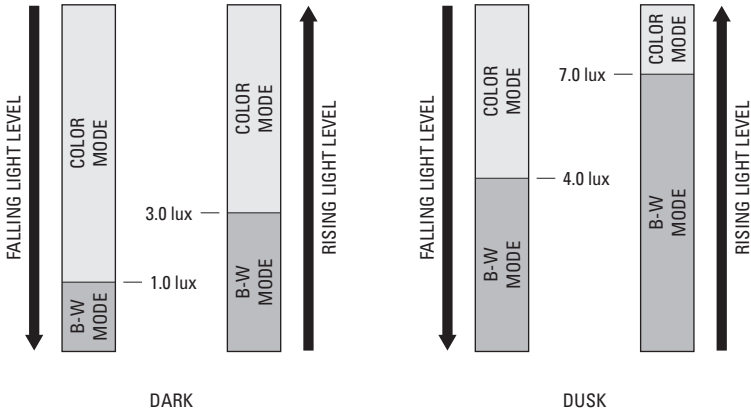

**Figure 11.** Threshold Switching Levels

**Table A.** Approximate Switching Thresholds

<b>Color to B-W</b>	1.5 lux $\pm$ 1.0 lux
<b>B-W to Color</b>	3.0 lux $\pm$ 1.0 lux

**NOTE:** These switching thresholds are approximate. Use the thresholds in Table A as a guide when installing the unit.

# DW/CW SERIES (WIDE DYNAMIC RANGE) ADJUSTMENTS

Refer to Figure 12 to adjust the IS110-DW or IS110-CW model.

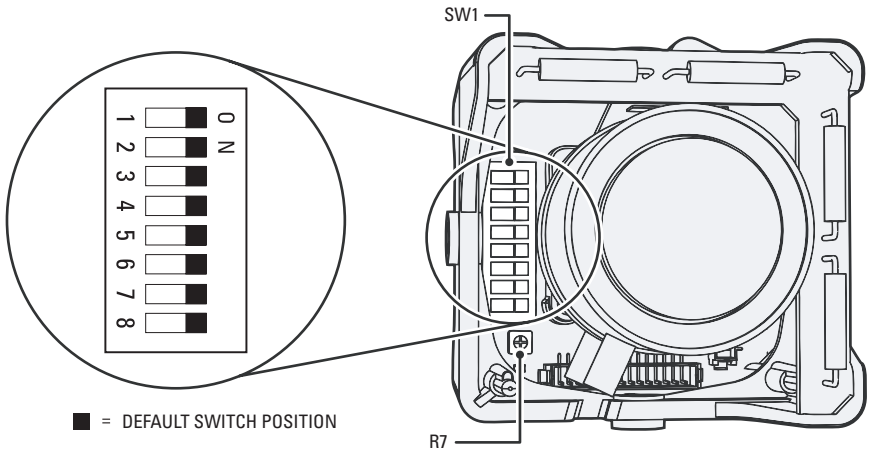

**Figure 12.** Adjusting the IS110-DW/CW Series Camclosure

## SWITCH SETTINGS

Locate the DIP switch. Then set the switches for your installation.

### SW1-1: Video Format

Set to ON for NTSC. Set to OFF for PAL. The default is ON.

### SW1-2: Line Sync

When multiple cameras are connected to the same switching device, vertical roll may occur on the monitor. AC line lock eliminates vertical roll by locking the frame rate to the power supply frequency. Each camera output is synchronized to the power supply frequency. (Refer to *Vertical Phase Adjustment* on page 27 for more information.)

Internal line sync disables line lock and synchronizes cameras internally.

Set to ON to use AC line lock. Set to OFF for internal line sync. The default is ON.

### SW1-3: Interlaced Scanning/Progressive Scanning

Interlaced scanning is the standard for analog recording installations. Each frame contains one odd and one even field, each processed separately.

Progressive scanning is better for digital recording installations. Each frame is processed as a whole, which results in less blurring and cleaner digital conversion. It also saves storage space on digital video recorders.

Set to ON to select interlaced scanning. Set to OFF to select progressive scanning. The default is ON.



## **SW1-4: AWB (Auto White Balance)/MWB (Manual White Balance)**

Auto white balance is enabled by default (ON).

To manually set and lock the white balance:

1. Set SW1-4 to ON.
2. Hold a white background in front of the lens until the video shows all white.
3. While holding the background in place, set SW1-4 to OFF. A green block and a white block alternate briefly on the video image until the manual white balance process is complete.

## **SW1-5: Fluorescent/General**

Enable this option to adjust the camera for best operation under fluorescent lighting.

Set to OFF for fluorescent lighting. Set to ON for general lighting. The default is ON.

**NOTE:** If you use fluorescent operation, you should use AC line lock for best results.

## **SW1-6: General WDR/Maximum WDR**

Maximum WDR supports about 36 dB of additional dynamic range over a standard camera. Use it for installations that require the maximum WDR.

General WDR supports about 20 dB of additional dynamic range over a standard camera. Use it for installations that do not require the maximum WDR.

Set to ON to select maximum WDR. Set to OFF to select general WDR. The default is ON.

## **SW1-7: DSS (Digital Slow Shutter)**

The default shutter speed for NTSC is 30 frames per second (fps). It is 25 fps for PAL. This is also known as SENS 2X.

You can decrease the shutter speed to 7.5 fps (NTSC) or 6.25 fps (PAL). This is known as SENS 8X, which improves low light sensitivity.

Set to ON to select SENS 2X. Set to OFF to select SENS 8X. The default is ON.

## SW1-8: Day/Night Operation (DW models only)

**NOTE:** On CW models, SW1-8 is unused and does not affect camera operation.

DW model cameras regularly check the brightness level of the field of view to determine when to switch between day (color) and night (black-white) operation. Use SW1-8 to set the general light levels at which the camera will automatically switch.

Set to ON (dark) to use standard thresholds to switch between color and black-white operation. This is the default.

Set to OFF (dusk) to use higher light thresholds to switch between color and black-white operation.

Actual brightness threshold levels are affected by camera angle, amount of zoom, field of view, lens, and type of lighting. The switching process lasts from seven to 10 seconds.

Figure 13 and Table B show how the camera switches between color and black-white operation for each setting.

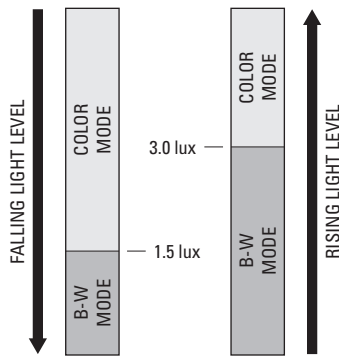

**Figure 13.** Threshold Switching Levels

**Table B.** Approximate Switching Thresholds

	<b>Dark (ON)</b>	<b>Dusk (OFF)</b>
<b>Color to B-W</b>	1.0 lux	4.0 lux
<b>B-W to Color</b>	3.0 lux	7.0 lux

**NOTE:** These switching thresholds are approximate and were measured using a 3.0 mm to 9.5 mm lens at F1.0. Use the thresholds in Table B as a guide when installing the unit.

## AUTO IRIS LEVEL ADJUSTMENT

The electronics of the IS110-DW and IS110-CW Series Camclosures automatically adjust the camera to the auto iris. Auto iris level adjustments are not necessary.

## VERTICAL PHASE ADJUSTMENT

**NOTE:** Use this procedure for 24 VAC operation only.

When using more than one camera power supply, a brief vertical roll may occur on the monitor when switching from one camera to another.

To eliminate vertical roll, reverse the 24 VAC connections on one camera. If both cameras are connected to the same transformer, this should solve the problem. If the problem still exists, adjust the phase control by synchronizing, or line-locking, the cameras to one another.

**NOTE:** When adjusting vertical phase, line sync (SW1-2) must be set to ON for AC line lock.

### Adjusting Vertical Phase

You may need two people when synchronizing the cameras: one at the camera, the other at the monitor to observe the vertical roll and the effect of any camera adjustments.

To synchronize the cameras:

1. Choose a reference camera to which all other cameras will be phased.
2. Select the camera to synchronize. Use the phase adjustment control (R7) to synchronize the camera to the reference camera (refer to Figure 12 on page 24). Turn R7 clockwise to increase vertical phase; turn R7 counterclockwise to decrease vertical phase.
3. Each time an adjustment is made, switch back and forth between the camera you are adjusting and the reference camera. Repeat this process as many times as necessary until the roll between the cameras is no longer noticeable.
4. Adjust the phase of all other cameras by repeating steps 2 through 3. Always adjust to the reference camera selected in step 1.

**NOTE:** The preferred method for camera phase adjustment is to use a dual trace oscilloscope to align the vertical sync pulses of the reference camera to the selected camera(s).

## BLEMISH DETECTION

If small white or color spots appear in the video image, one or more pixels on the camera imager may be defective. (This condition is common for both CCD and CMOS imagers.)

DW and CW Series cameras have auto iris lenses and automatically detect and correct defective pixels during startup. Manual pixel correction is not available.

# Camera Positioning

Rotate and tilt the camera module to position the camera. Then tighten the tilt screws (axis 1 in Figure 14).

**NOTE:** Do not over-rotate the module. Excessively turning the module in one direction could result in damage to the wiring.

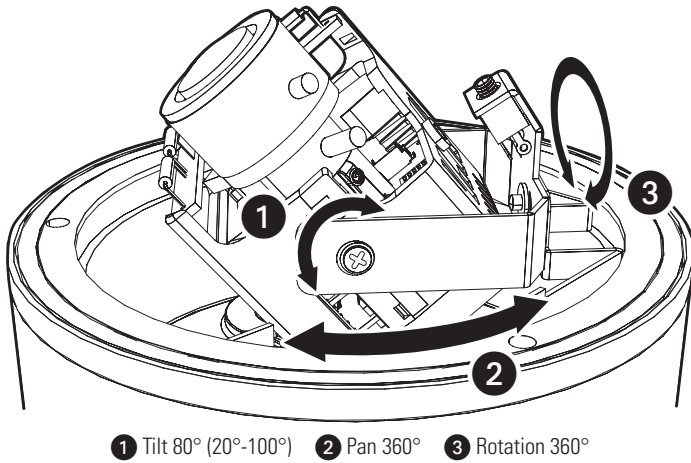
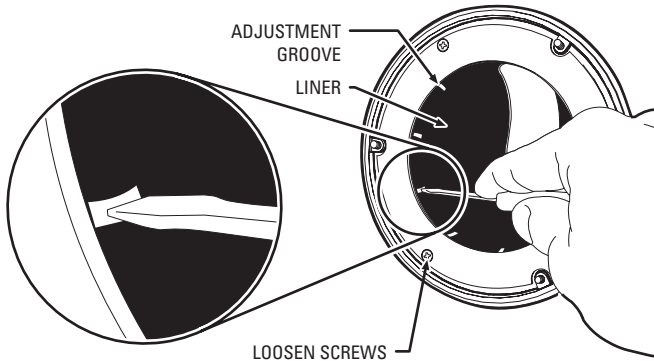

**Figure 14.** Positioning the Camera

# Install Liner and Trim Ring

---

1. Adjust the liner if installed (refer to Figure 15):
  - a. Align the screw holes in the trim ring with those in the back box to identify the proper liner position.
  - b. Loosen the three Phillips screws located in the trim ring.
  - c. Insert the blade of a standard screwdriver in one of the adjustment grooves. Rotate the liner to position the viewing window over the camera lens.
  - d. Tighten the three Phillips screws to lock the liner in place.



**Figure 15.** Adjusting the Liner

2. Align the screw holes in the trim ring with those in the back box.
3. Tighten the tamper-resistant screws through the trim ring into the back box. Use the supplied 1/8-inch hollow screwdriver bit.

# Service Connector

---

The IS110 Series Camclosure integrated camera system includes a service connector that outputs camera video. Use it at the installation site to set up the field of view and focus the camera.

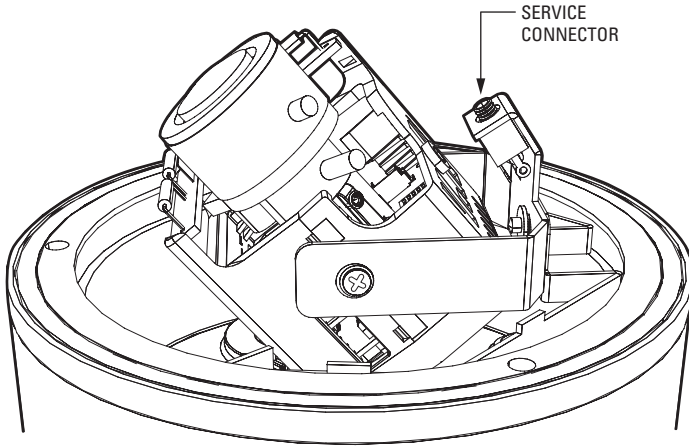

**Figure 16.** Service Connector

Pelco offers two optional items that plug directly into the service connector. Before using either option, you must loosen the tamper-resistant screws to remove the trim ring from the back box. Use the supplied 1/8-inch hollow screwdriver bit.

The optional CST150 has a 3-foot (0.9 m) cable and microdisplay for viewing camera video. Plug it into the service connector and view the video.

**NOTE:** The three buttons on the CST150 are not used with the IS110 Series Camclosure.

The optional ICS-SC is a 4-foot (1.2 m) cable with a service connector and a BNC connector. Plug the cable into the service connector on the IS110. Then connect the other end to any standard BNC (VIDEO IN) connector on a monitor.

To assemble a longer service cable for the Camclosure integrated camera system, purchase the following from a local electronics supply store:

- 12.5 mm monaural headphone plug
- 1 CPM 88 miniature coaxial connector
- 1 RG174/U coaxial cable

To assemble the cable:

1. Attach the CPM 88 miniature coaxial connector to one end of the cable. Follow the directions supplied with the miniature coaxial connector.
2. Attach the 2.5 mm monaural plug to the other end of the coaxial cable (refer to Figure 17):
  - a. Remove the support sleeve from the plug.
  - b. Slip the support sleeve over the end of the cable.
  - c. Prepare the cable.
  - d. Solder the center conductor of the cable to the center pin of the plug.
  - e. Thread the braid of the cable through the hole in the crimp pin.
  - f. Solder the braid to the top of the crimp pin.
  - g. Crimp the end of the crimp pin around the cable.
  - h. Reassemble the support sleeve and the plug.

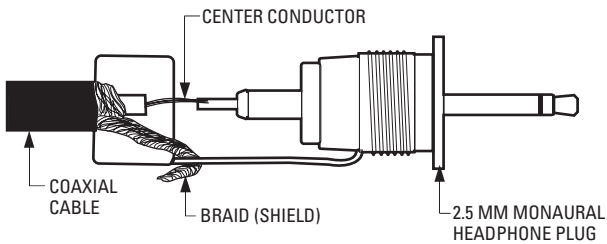

**Figure 17.** Attaching the 2.5 mm Monaural Headphone Plug

# Specifications

---

## GENERAL

Pan/Tilt Adjustment	Manual
Pan	360°
Tilt	80° (20° to 100° range)
Rotation	360°
Construction	Aluminum with steel camera mounting bracket and polycarbonate dome
Cable Entry	One 0.75-inch (1.91 cm) NPT threaded opening on side; two 0.75-inch (1.91 cm) openings on base
Finish	Gray polyester powder coat
Light Attenuation	
Smoked	1.5 F-stops light loss
Clear	Zero light loss
Unit Weight	2.2 lb (1.0 kg)

## ELECTRICAL

Input Voltage*	12 VDC or 24 VAC (±10%), autosensing
Synchronization	Internal or AC line lock
Power Consumption	
Camera	<3 W (DW/CW models) <4 W (DN/CH models)
Heaters	10 W when active, thermostatically controlled

\*24 VAC power is recommended when installing any Camclosure Integrated Camera System under fluorescent lighting conditions.

## VIDEO

Signal System	NTSC or PAL
Video Output	
Composite	1 Vp-p (75 ohms)
UTP	1 Vp-p (100 ohms)
Video Connectors	1 composite BNC and 1 UTP
Service Connector	3-conductor, 2.5 mm connector for video output to optional ICS-SC cable

## ENVIRONMENTAL

Environment	Low temperature, indoor/outdoor
Operating Temperature	-50° to 122°F (-46° to 50°C); de-ices to 25°F (-4°C)
Thermostat Operation	Heater is thermostatically controlled to activate ON at 50°F (10°C) and OFF at 80°F (27°C)

## CAMERA/LENS

If you need technical specifications for the camera itself, refer to the IS110 specification online at [www.pelco.com](http://www.pelco.com).

*(Design and product specifications subject to change without notice.)*



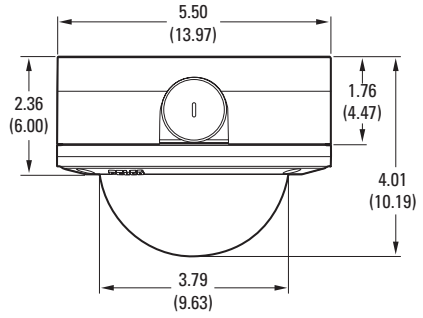
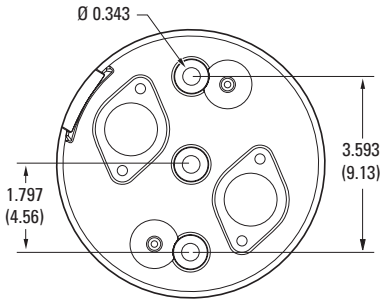

NOTE: VALUES IN PARENTHESES ARE CENTIMETERS;  
ALL OTHERS ARE IN INCHES.



# PRODUCT WARRANTY AND RETURN INFORMATION

## WARRANTY

Pelco will repair or replace, without charge, any merchandise proved defective in material or workmanship **for a period of one year** after the date of shipment.

Exceptions to this warranty are as noted below:

- Five years on fiber optic products and TW3000 Series unshielded twisted pair transmission products.
- Three years on Spectra® IV products.
- Three years on Genex® Series products (multiplexers, server, and keyboard).
- Three years on Camclosure® and fixed camera models, except the CC3701H-2, CC3701H-2X, CC3751H-2, CC3651H-2X, MC3651H-2, and MC3651H-2X camera models, which have a five-year warranty.
- Three years on PMCL200/300/400 Series LCD monitors.
- Two years on standard motorized or fixed focal length lenses.
- Two years on Legacy®, CM6700/CM6800/CM9700 Series matrix, and DF5/DF8 Series fixed dome products.
- Two years on Spectra III™, Esprit®, ExSite®, and PS20 scanners, including when used in continuous motion applications.
- Two years on Esprit and WW5700 Series window wiper (excluding wiper blades).
- Two years (except lamp and color wheel) on Digital Light Processing (DLP®) displays. The lamp and color wheel will be covered for a period of 90 days. The air filter is not covered under warranty.
- Eighteen months on DX Series digital video recorders, NVR300 Series network video recorders, and Endura™ Series distributed network-based video products.
- One year (except video heads) on video cassette recorders (VCRs). Video heads will be covered for a period of six months.
- Six months on all pan and tilts, scanners or preset lenses used in continuous motion applications (that is, preset scan, tour and auto scan modes).

Pelco will warrant all replacement parts and repairs for 90 days from the date of Pelco shipment. All goods requiring warranty repair shall be sent freight prepaid to Pelco, Clovis, California. Repairs made necessary by reason of misuse, alteration, normal wear, or accident are not covered under this warranty.

Pelco assumes no risk and shall be subject to no liability for damages or loss resulting from the specific use or application made of the Products. Pelco's liability for any claim, whether based on breach of contract, negligence, infringement of any rights of any party or product liability, relating to the Products shall not exceed the price paid by the Dealer to Pelco for such Products. In no event will Pelco be liable for any special, incidental or consequential damages (including loss of use, loss of profit and claims of third parties) however caused, whether by the negligence of Pelco or otherwise.

The above warranty provides the Dealer with specific legal rights. The Dealer may also have additional rights, which are subject to variation from state to state.

If a warranty repair is required, the Dealer must contact Pelco at (800) 289-9100 or (559) 292-1981 to obtain a Repair Authorization number (RA), and provide the following information:

1. Model and serial number
2. Date of shipment, P.O. number, Sales Order number, or Pelco invoice number
3. Details of the defect or problem

If there is a dispute regarding the warranty of a product which does not fall under the warranty conditions stated above, please include a written explanation with the product when returned.

Method of return shipment shall be the same or equal to the method by which the item was received by Pelco.

## RETURNS

In order to expedite parts returned to the factory for repair or credit, please call the factory at (800) 289-9100 or (559) 292-1981 to obtain an authorization number (CA number if returned for credit, and RA number if returned for repair).

All merchandise returned for credit may be subject to a 20% restocking and refurbishing charge.

Goods returned for repair or credit should be clearly identified with the assigned CA or RA number and freight should be prepaid. Ship to the appropriate address below.

*If you are located within the continental U.S., Alaska, Hawaii or Puerto Rico, send goods to:*

Service Department  
Pelco  
3500 Pelco Way  
Clovis, CA 93612-5699

*If you are located outside the continental U.S., Alaska, Hawaii or Puerto Rico and are instructed to return goods to the USA, you may do one of the following:*

If the goods are to be sent by a COURIER SERVICE, send the goods to:

Pelco  
3500 Pelco Way  
Clovis, CA 93612-5699 USA

If the goods are to be sent by a FREIGHT FORWARDER, send the goods to:

Pelco c/o Expeditors  
473 Eccles Avenue  
South San Francisco, CA 94080 USA  
Phone: 650-737-1700  
Fax: 650-737-0933

## REVISION HISTORY

Manual #	Date	Comments
C3426M	2/07	Original version.
C3426M-A	5/07	Updated switch setting and day/night operation descriptions.

Pelco, the Pelco logo, Camclosure, Esprit, ExSite, Genex, Legacy, and Spectra are registered trademarks of Pelco. Endura and Spectra III are trademarks of Pelco. DLP is a registered trademark of Texas Instruments, Inc.

©Copyright 2007, Pelco.  
All rights reserved.



Worldwide Headquarters  
3500 Pelco Way  
Clovis, California 93612 USA

USA & Canada  
Tel: 800/289-9100  
Fax: 800/289-9150  
International  
Tel: 1-559/292-1981  
Fax: 1-559/348-1120

[www.pelco.com](http://www.pelco.com)

ISO9001

Australia | Canada | Finland | France | Germany | Italy | Macau | The Netherlands | Russia | Singapore  
South Africa | Spain | Sweden | United Arab Emirates | United Kingdom | United States